

fancort industries, inc.

TM

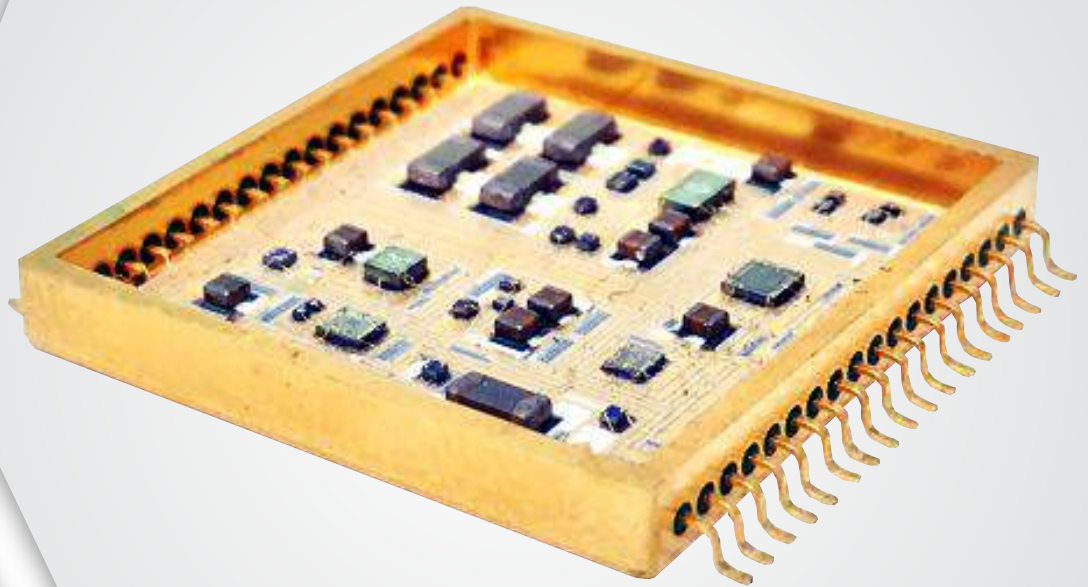

SMT Lead Forming

Equipment and Services

SMT Component Preparation Services



Overview

Fancort is the industry leader in component lead forming for Aerospace and semiconductor industries with more than 44 years experience designing tooling to form and trim leads for a wide variety of electronic devices into innumerable configurations. We use our unique universal lead forming systems and complete process control to ensure accuracy and quick turnaround. Mil-Spec lead tinning on our LTS 2000 automated equipment is available for any type of FLAT MILSPEC devices. Leak testing is another option we offer.

Features

- ▶ Lead forming to Mil-std 883E and NASA std FP 51 3414 Rev. H Section 3
- ▶ Process control incorporates all ISO requirements
- ▶ Standard footprints layouts are available, or we will design
- ▶ your custom footprint.

Options

- ▶ Lead tinning to Mil std NASA std 8739.2 8199 "workmanship standard for SMT" and Mil 2009 7.
- ▶ Tinning is double dip method: No flux, tin to remove gold, flux and final tin.
- ▶ Tinning per J-STD-00/ES for space grade parts.
- ▶ Leak testing to Mil-std 883, Med + Mod 1014.12, conditions A and C, gross and fine.
- ▶ Fancort's adjustable matrix trays for storage and shipping.



**LTS 2000
Robotic Tinning Machine**

Universal One-sided SMT Form and Trim Systems

Overview

One-sided universal lead forming systems are the most flexible and accurate in the industry for processing a wide variety of components to most standards footprints. This equipment is ideal for high-mix and short run requirements.

Features

- ▶ Forms a gullwing configuration on most one, two and four-sided packages.
- ▶ Adjustable backstop with linear slide holds the package case parallel for accurate registration.
- ▶ All models can process top brazed, side exit or bottom brazed packages.
- ▶ Built-in digital micrometers on all models for easy setup of trim length and standoff height. Inch and metric readouts are standard.
- ▶ Easy to change die members for large variations in lead materials thickness hardness or shape.
- ▶ Standard models handle packages up to 2.5" in length; larger models for packages up to 4" in length.

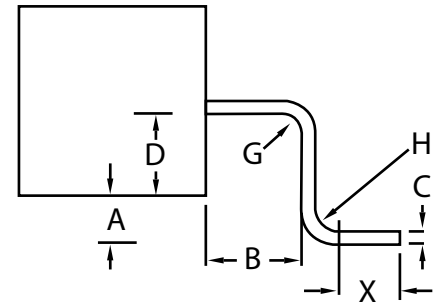

F-1B/1 and 3300 press



F-1B/3A and 5000L air press

SMART FLEX™ two-sided SMT lead form and trim system with automatic standoff control and PLC controlled

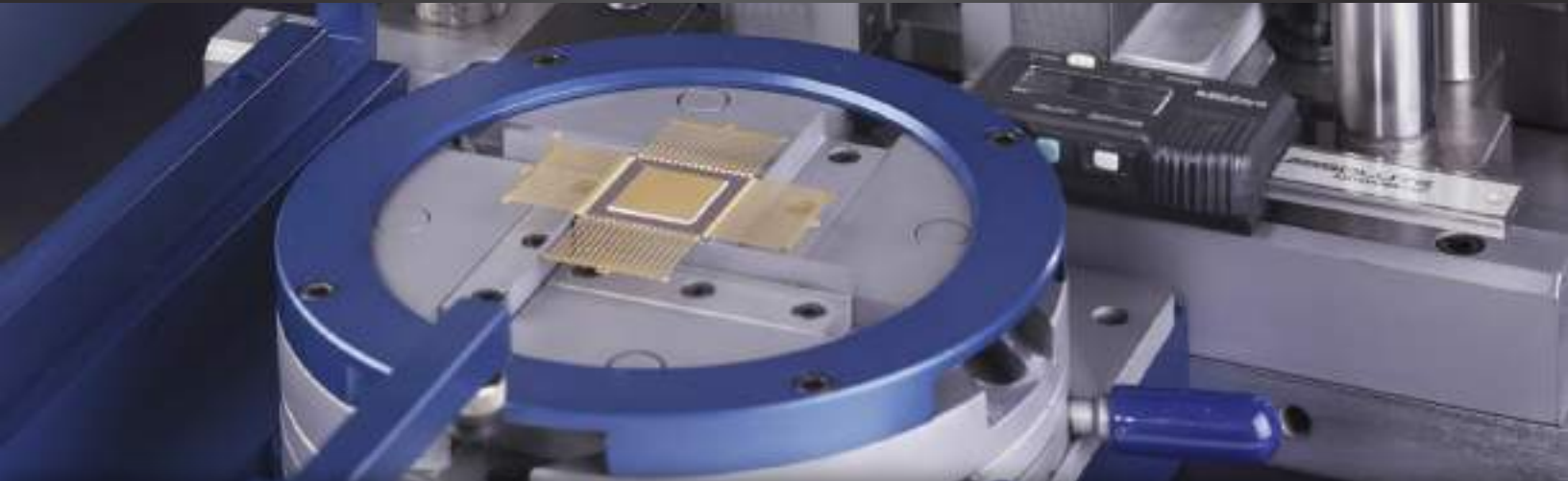

FLEX™

Overview

The FLEX™ is a two-sided gullwing lead forming system with automatic standoff control. Simple changeover of die members, combined with accurate, repeatable changes in tip to tip length, can vary all the critical dimensions of most SMT footprints on a wide variety of ceramic packages.

Features

- ▶ Automatic standoff control (B) to $\pm .002$ " when used with the Fancort floating anvil press.
- ▶ Removable die members for varying all critical dimensions such as shoulder, foot, radii and lead material thickness without removing the tool from the press.
- ▶ Adjustable tip to tip length using hand control with precision ball screw with anti-backlash and digital readout.
- ▶ Centering station with manual loader for error free throughput and the most accurate hands-free operation.
- ▶ Patent number 4,907,628.

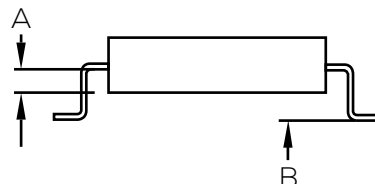
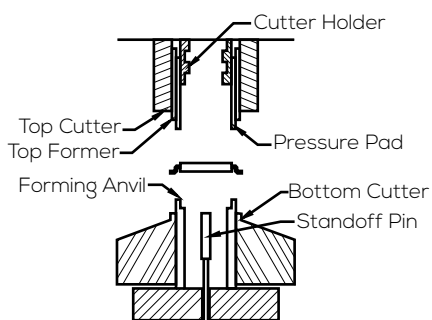

SMART FLEX™

Dedicated SMT Tooling

Overview

Dedicated tooling is designed for tighter tolerance lead forming and less part handling than Fancort universal lead forming systems. These tools process all sides of a two or four-sided package at one time. They are available with manual standoff control, or our patented electronic floating anvil system for automatic standoff control. Both types of tools produce a coplanarity of .004" or better, per JEDEC specification.

Automatic Standoff Control

Fancort state of the art patented floating anvil system incorporates a precision stepper motor control system built into the press to automatically position the moveable forming anvils each time the press cycles. This feature produces a constant standoff (B) regardless of the lead exit position (A) or body thickness to a tolerance of +/- .002".

Manual Standoff Control

These tools require manual setting of a built-in, lockable micrometer to set the standoff height, and a lifter mechanism for easy part removal for quadpacks.

Options

- ▶ Integrated corner cutting for devices with metal or nonconductive tie bars.
- ▶ Manual tool loader for semiautomatic part handling.



F-1A Manual tools for FP & QP



F-1F Floating dedicated tools for FP & QP

Lead Cutter

Flatpacks and Quadpacks- Adjustable #F-3 Series

- ▶ Trim leads on packages up to 3" in length.
- ▶ Adjusts easily to various case sizes with movable, locking nest.
- ▶ Tapered shear to eliminate stress and smooth cutting.
- ▶ Built-in micrometer to set cut length from .080" to .500"
- ▶ Optional model to cut corners on packages with non-conductive tie bars, #F-3C/A

Flatpacks and Quadpacks #F-3 or F-3/4

- ▶ Dedicated lead cutters to cut all sides of a package at one time, two or four-sided.
- ▶ Lifter built-in if required for easy part removal on quadpacks. P/N F-3/4 Series.

Through-Hole Components

Pneumatic lead cutters, standard or large models, tapered shear for reduced stress, scrap bin and custom made precision tooling plates for cutting leads on almost any through-hole component including connectors with heavy leads. P/N D-2C standard.

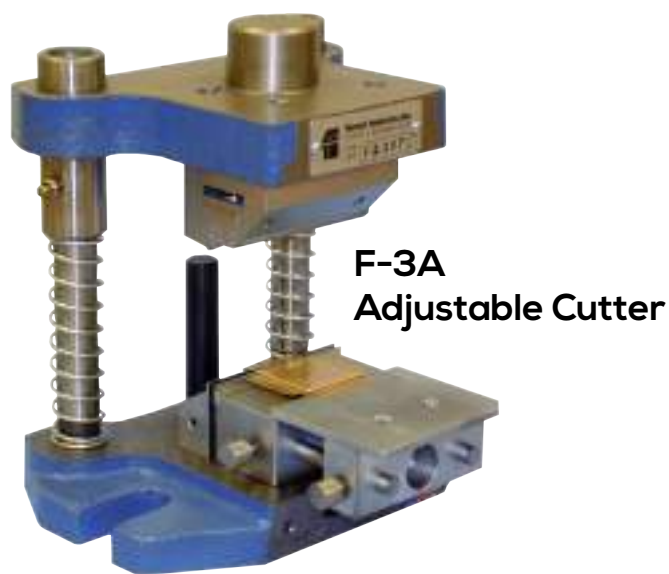

Optional large model D-2C/L

Dedicated Lead Cutter F-3/4

Production Accessories

Adjustable Matrix Trays



Reusable aluminum tray with moveable ESD safe supports for most two and four sided packages. Each tray comes with a cover with ESD foam in a static shielded bag that fastens securely to the base. Each tray holds up to 10 devices. P/N AMT- 6x12QP or FP.

Standoff Measuring Tool

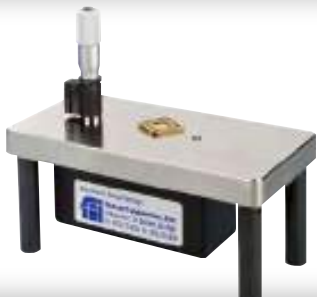

A precision instrument measures the finished standoff height on any surface mounted device, simply and accurately. It can also be used to measure the lead exit position on an unformed device so you can set the standoff control on Fancort form and trim tools. HC-1.

Coplanarity Mirror



A precision tool used to visually inspect leads on each side of a formed device for coplanarity. The optically perfect mirror is angled on the tool so the operator can easily perform this inspection procedure. Small and compact, it measures 4" x 4". P/N CI-1.

Heavy Duty Vacuum Pen

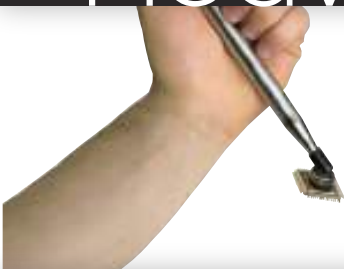

This vacuum pen is designed for use with heavier packages that require extra holding power for loading into Fancort tools. It comes with three vacuum cups of different diameter and the tip is angled for ease of use. P/N: HP-100.

Custom Applications

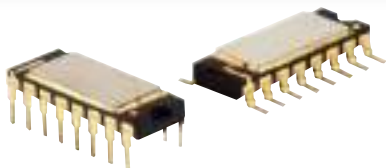

Through-hole DIP to SMD

Fancort will design and build tooling for a wide variety of complex lead forming requirements. Here are some examples of the types of tooling we've built.

Contact us to discuss your application.



fancort industries, inc. TM

Custom Applications



Omega-style Bend



Reverse Gullwing



Staggered Through-hole

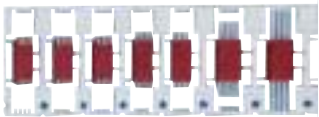

Progressive Lead Frame

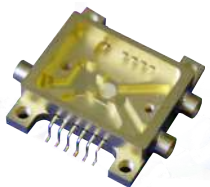

Fiber Optic Device

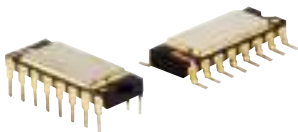

Through-hole DIP to SMD

Custom Applications
Can Form



Roller Forming

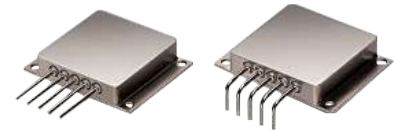

Optical Component Forming

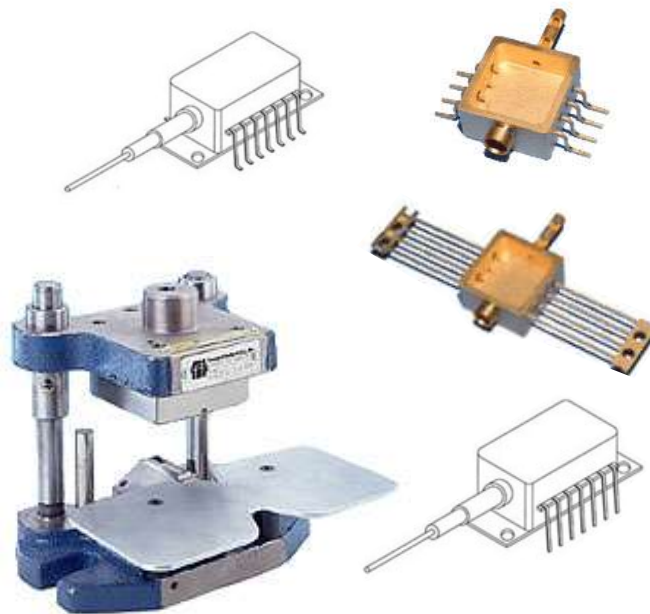

Custom Application
Omega-Style Bend

TO-220 One-Sided Omega Bend



www.fancort.com

31 Fairfield Place West Caldwell, NJ 07006

sales@fancort.com

(P) 1.888.FANCORT

(P) 973.575.0610