

fancort Industries, Inc.

31 FAIRFIELD PLACE

WEST CALDWELL, N.J. 07006

(973) 575-0610

WWW.FANCORT.COM

FAX (973) 575-9234

NASA VERSION

QUAD PACK SPECIFICATION SHEET

JOB NUMBER _____

MANUFACTURER ACTEL

PART NUMBER 352QP

DATE 8/2/10

DRAWN BY FANCORT BC

CHECKED BY _____

PACKAGE TYPE

TOP BRAZE

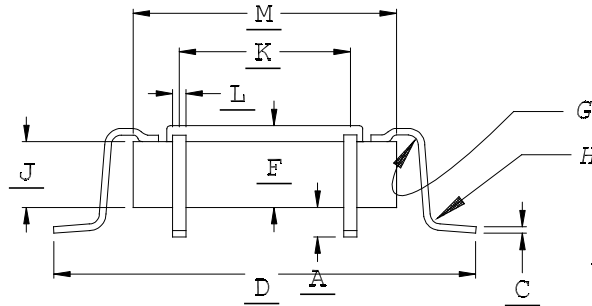

FOOT CONFIGURATIONS

SPRING BACK
ANGLE 3°-7°

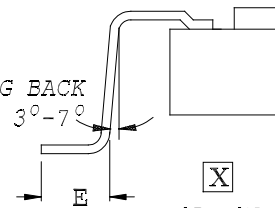

OPTION 1

SIDE EXIT

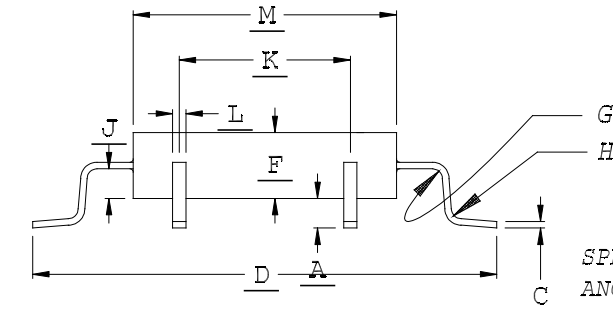

SPRING BACK
ANGLE 3°-7°

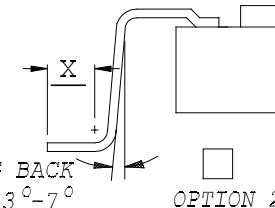

OPTION 2
JEDEC

BOTTOM EXIT

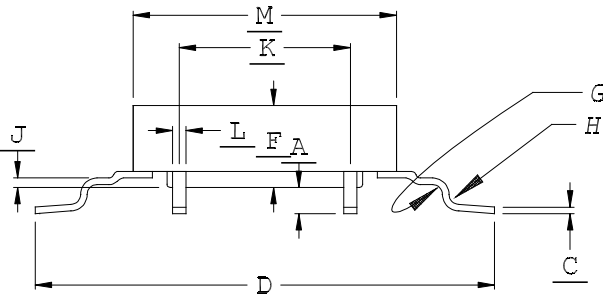

OPTION 1

OPTION 2

	DIM. I	DIM. F	TOLERANCE
A	.010	.010	.002
C	.007	.007	MAX
D	2.100	2.100	.010
E	.056	.056	.005
OPTION 1			
OPTION 2			
F	.114	.114	MAX
G	.010	.010	.002
H	.010	.010	.002
J	.090	.090	.009
K	1.713	1.713	BSC
L	.0086	.0086	MAX
M	1.900	1.900	MAX
PITCH	.0197	.0197	
# OF LEADS PER SIDE	88	88	
TOTAL # OF LEADS	352		

CUSTOMER SIGNATURE &
DATE FOR ACCEPTANCE _____

CONTROLLING UNITS ARE [METRIC] INCHES

LEADS TINNED YES NO

LEAD TYPE: FLAT

PACKAGE TYPE: METAL

ROUND

CERAMIC

UP 0°-4°

PLASTIC

TOE DOWN 0°-4°

GLASS SEAL