

fancort Industries, Inc.

31 FAIRFIELD PLACE

WEST CALDWELL, N. J. 07006

(973) 575-0610

WWW.FANCORT.COM

FAX (973) 575-9234

FLAT PACK SPECIFICATION SHEET

FA NUMBER _____

CUSTOMER _____

PART NUMBER **Maxwell 32 lead FP**

DATE **11/25/08**

DRAWN BY FANCORT _____

CHECKED BY _____

PACKAGE TYPE

TOP BRAZE

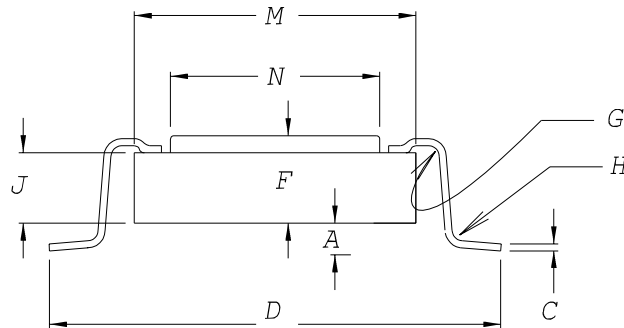

FOOT CONFIGURATIONS

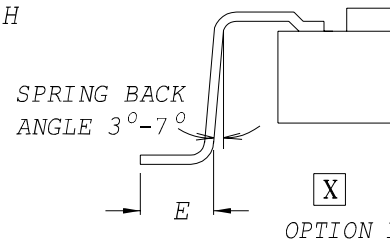

SIDE EXIT

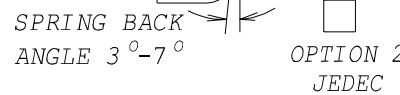
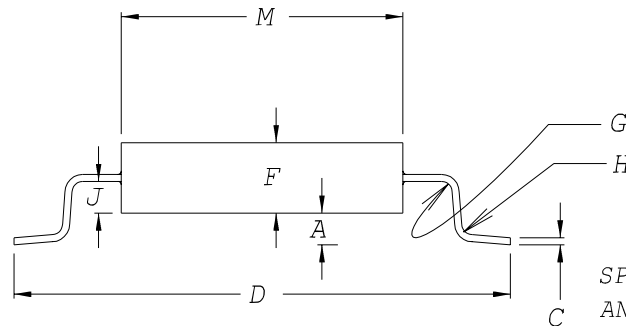

BOTTOM EXIT

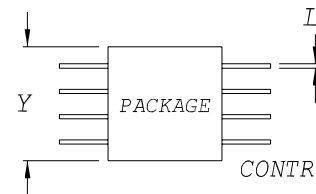
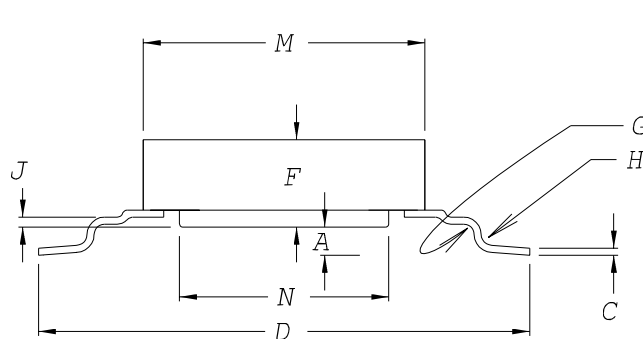

CUSTOMER SIGNATURE & DATE FOR ACCEPTANCE _____

CONTROLLING UNITS ARE [METRIC] INCHES

LEADS TINNED YES NO

LEAD TYPE: FLAT

PACKAGE TYPE: METAL

ROUND

CERAMIC

TOE UP 0°-4°

PLASTIC

DOWN 0°-4°

GLASS SEAL

	DIM	TOLERANCE
A	.010	.002
C	.009	MAX
D	.626	.010
E	.050	.005
OPTION 1	X	-----
OPTION 2	X	-----
F	.143	MAX
G	.012	.002
H	.012	.002
J	.035	+0.010/ .015
M	.416	MAX
N	.240	NOM
PACKAGE LENGTH	Y	.830 MAX
LEAD WIDTH	L	.022 MAX
PITCH		.050
# OF LEADS PER SIDE		16