

fancort industries inc.

31 FAIRFIELD PLACE, WEST CALDWELL NJ 07006 973-575-0610

TOLERANCES U.D.S.	DESCRIPTION SPRINGBACK VS. MIC SETTING					
DECIMAL .XXXX .0002	DATE 11/18/09	DRAWN BY BC	SCALE APPROVED BY			
DECIMAL .XXX .002	PRODUCT ALL TOOLS				SHEET/LEVEL	
FRACTION +/- .015	DRAWING #				SERIAL #	
ANGULAR +/- .5	DATE	REV	E.C.O. #	AUTH	BY CK	

MATERIAL SPRINGBACK MUST BE COMPENSATED FOR IN MICROMETER SETTING. TOOL IS SET TO ZERO AT FACTORY,

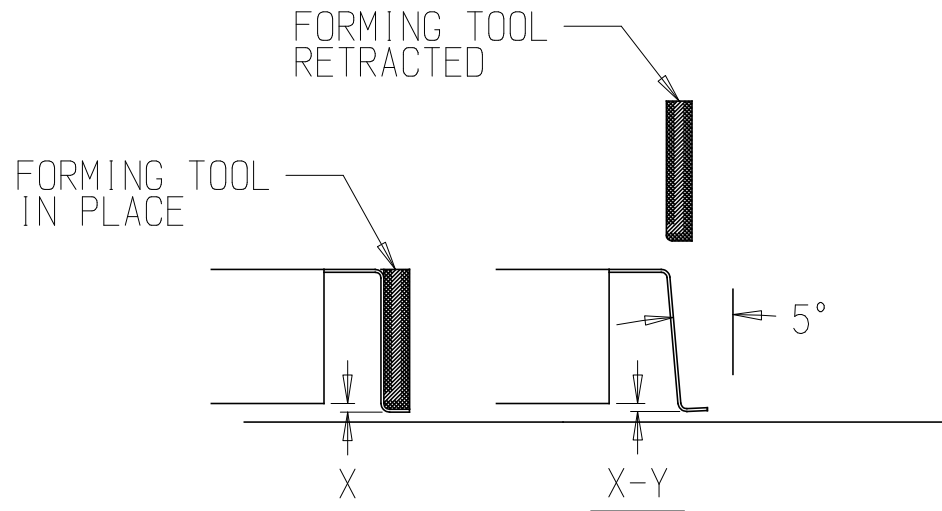

X = SETTING ON MICROMETER

Y = MATERIAL SPRINGBACK