

fancort industries, inc.

TM



PCB Laser Marking

Automatic Applications

PCB Laser Marking

Laser Applications in PCB Industry

PCB Marking



PCB Cutting

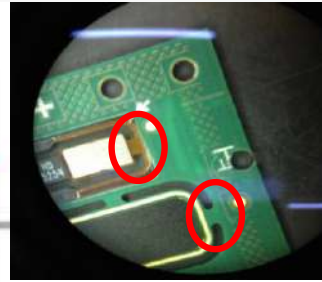

The Laser Marking Process

Laser marking is what happens when the beam interacts with the surface of a material, slightly altering its properties or appearance.

- ▶ It is achieved by moving a low-powered beam slowly, which creates high-contrast marks without disrupting the material.
- ▶ Laser heats the material, causing oxidation under the surface and turning the material black.
- ▶ It applies low temperatures to metal to anneal the surface.
- ▶ All of this is done while leaving the surface intact.



PCB Laser Marking

Processing Comparison

Laser Marking

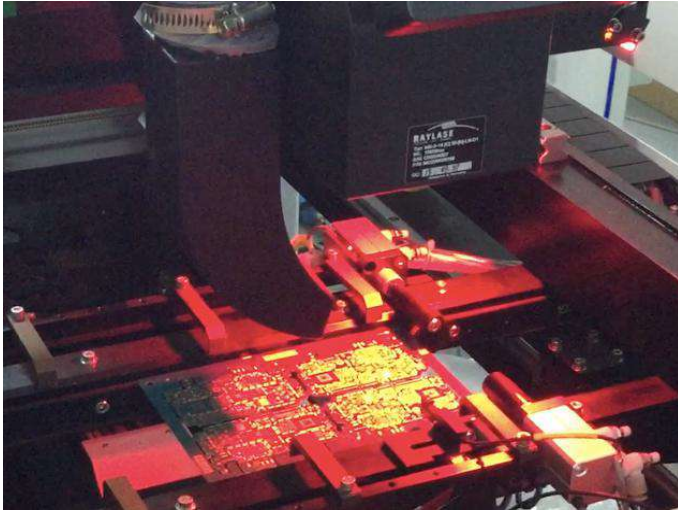

- ▶ Fully Automated
- ▶ High Efficiency
- ▶ No Consumables
- ▶ High Precision
- ▶ Stable Quality
- ▶ Permanent Marked
- ▶ Environment Friendly

Paper Label



- ▶ Manual Process
- ▶ Low Efficiency
- ▶ Consumables Cost
- ▶ Low Precision
- ▶ Inconsistent Quality
- ▶ Label Adherence
- ▶ Pollution

Cost Comparison

- ▶ Cost savings from no consumables: High volume manufacturers can greatly reduce costs with laser marking, which only costs \$0.02 per mark, compared to \$0.07-\$0.09 per mark for ink or labels. The consumable cost for ink or labels will far exceed the initial cost of laser.
- ▶ Permanence: Stickers fall off and ink fades, but when you use laser marking, you have a permanent mark that will stand the test of time. That means even if you are marking a part that won't need replacing for five, ten or twenty years, you will be able to read that part number or scan its barcode.
- ▶ Minimal maintenance: Avoid downtime associated with cleaning or unclogging a printer when you utilize laser marking systems that don't use messy consumables.

PCB Laser Marking

Equipment Feature



- ▶ Standard config. CO2 laser, optional for fiber UV or Green laser.
- ▶ Automatic marking with a high precision and efficient CCD positioning system, which is able to check the codes after the marking process.
- ▶ Conveyor connects with SMT production lines or with an offline components feeder.
- ▶ Friendly HMI, and easy to operate. Able to connect with the user's own data system.
- ▶ Customization is possible.

Equipment Structure

Single Head

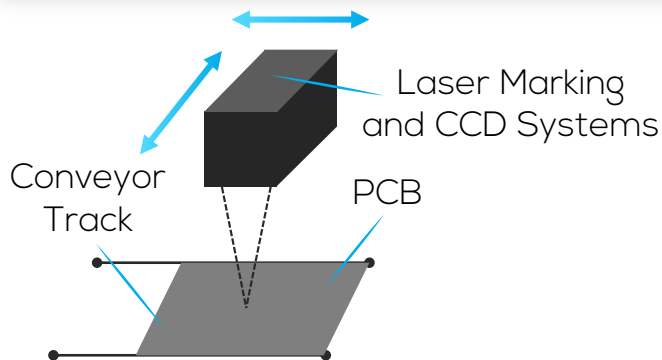

- ▶ Laser head moves along X, Y axis to mark on a larger area.
- ▶ PCB is moved on conveyor and positioned with the CCD system.
- ▶ Single laser head provides PCB one sided marking.

Two Side Marking

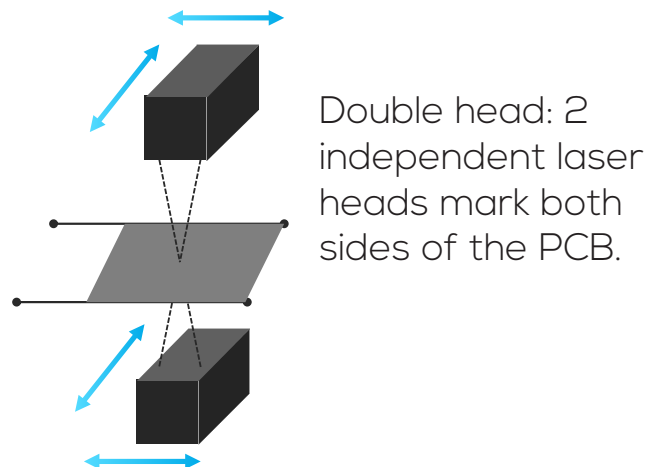
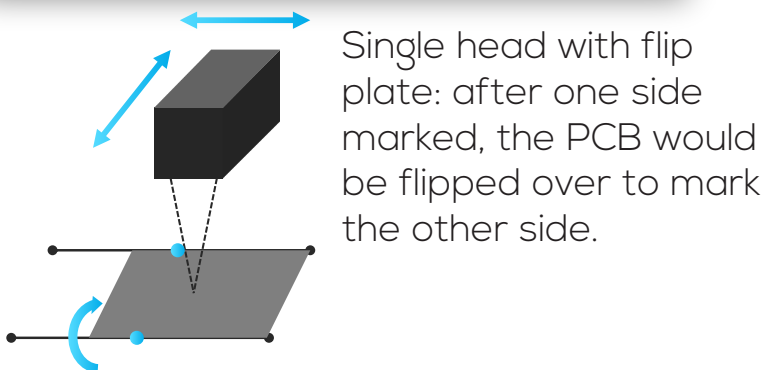

PCB Laser Marking

Configurations

Hardware

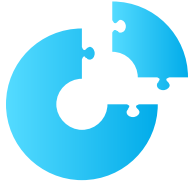

- ▶ Laser Source: CO2/Fiber/Green/UV
- ▶ Vision System: CCD Positioning, Code Checking.
- ▶ Platform: High precision linear motion module and, conveyor track.
- ▶ Automation: Conveyor width is adjustable; electric focusing system is optional.
- ▶ Auxiliary Device: Deduster.
- ▶ Communication Protocol: Standard SMEMA interface.

Key Numbers



- ▶ Marking Size: 50 x 50 mm ~ 460 x 510 mm.
- ▶ PCB Thickness: 0.3 mm ~ 5 mm.
- ▶ Marking Precision: ± 0.1 mm.
- ▶ Minimum Beam Dia.: 100um.
- ▶ Device Size: 1,000 mm (W) x 1,600 mm (D) x 1,500 mm (H).
- ▶ Conveyor Height: 870 mm - 930 mm
- ▶ Conveyor Running Director: L-R/R-L

Software Features

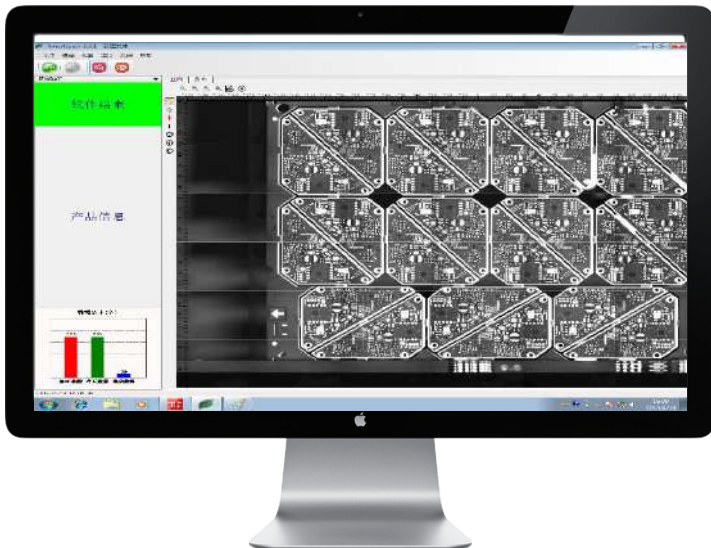

- ▶ Friendly HMI, fast programming, coordinates template editable with the imported information.
- ▶ Positions automatically with the feature points on the PCB, and is able to recognize the 2 sides of the PCB.
- ▶ Download marks data automatically from the information system.
- ▶ Checks the barcode after marking and feeds the information back.
- ▶ Waste PCB recognition and avoids remarking
- ▶ Real time display of the marking results, and outputs the production statistical data.

PCB Laser Marking

Scene Pictures

Offline Production



Online Production



Customized Equipment



1.- Product Introduction.

Two laser heads to mark both sides of a PCB, load and unload the plate with vacuum suction in two feeding lines. CT: 500 mm x 500 mm PCB, marks on both sides, 2 marks on each side, 4 second per PCB.

2.- Technical Feature.

- ▶ Two workplaces switching mode, and marks both sides at the same time with two laser heads.
- ▶ Vacuum suction does not damage the PCB plate.
- ▶ Device size: 2,300 mm * 1,900 mm * 1,600 mm.

PCB Marker



- ▶ Two workplaces and two laser heads.
- ▶ Vacuum suction for loading the PCB.

High Efficiency for irregular PCB



- ▶ Linear motion module.
- ▶ Marks both sides of the PCB.
- ▶ Marking area (≥ 500 mm * 500 mm).

PCB Laser Marking

Material Analysis and Marking Results

PCB Material Analyze

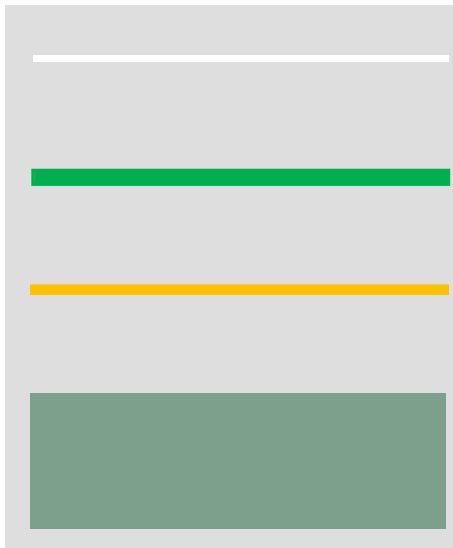

Silkscreen layer, the white oil, thickness 10~20 μm .

Solder mask layer, green oil, thickness 15~25 μm .



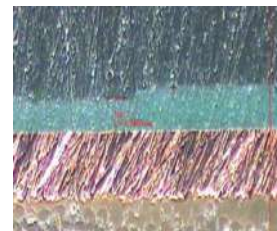
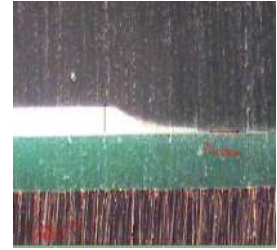

Circuit layer, copper layer, thickness 15~35 μm .



PCB is composite material, in which different elements react differently to the laser, so the laser source and parameters should be properly selected to achieve the best results.

Marking Area Slice Observation

Introduction of Laser Source

Laser Source	CO2	Fiber	Green Laser	UV Laser
Marking Feature	Widely applicable, No damage to circuits.	Metal and plastic materials markable.	Applicable for variety of materials, very high quality of light beam, high precision marking.	Applicable for variety of materials, very high quality of light beam, high precision marking.
Minimum Size	2 mm x 2 mm	1.5 mm x 1.5 mm	0.5 mm x 0.5 mm	0.5 mm x 0.5 mm
Applicable Material	Paint layer marking.	PCB frame and metal, plastic components.	Compatible for PCB, paint, metal and plastic material marking.	Compatible for variety of material, especially for white paint marking.
Sample Pictures	 4 mm x 4 mm	 4 mm x 4 mm	 0.6 mm x 0.6 mm (200 times magnification)	 5 mm x 5 mm

Samples



2D Barcode on Green Solder Mask



2D Barcode Details



2D Barcode on Blue Solder Mask



Barcode on White Solder Mask



2D Barcode on White Solder Mask



2D Barcode on Black Solder Mask



Barcode on Green Solder Mask (Green Laser)



2D Barcode on White Solder Mask (UV Laser)



Marking on Plastic Material



Shielding Case Marking

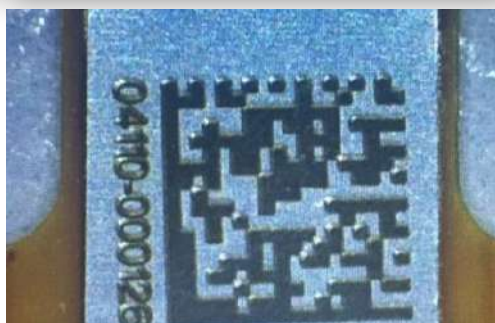

Marking on PCB Stiffeners



2D Barcode on Gilded Parts (Size 0.7 mm x 0.7 mm)

www.fancort.com